

5. a) What do you understand by state variable?
 b) Discuss relationship between state equation and transfer function.
 c) Discuss concept of controllability and observability with examples.
 d) Explain the properties of State transition matrix.

OR

Find $f(A) = A^7$ for $A = \begin{bmatrix} 0 & 3 \\ -2 & -5 \end{bmatrix}$

Roll No

EC - 502
B.E. V Semester
 Examination, June 2016
Control Systems

*Time : Three Hours**Maximum Marks : 70*

- Note:** i) Answer five questions. In each question part A, B, C is compulsory and D part has internal choice.
 ii) All parts of each question are to be attempted at one place.
 iii) All questions carry equal marks, out of which part A and B (Max. 50 words) carry 2 marks, part C (Max. 100 words) carry 3 marks, part D (Max. 400 words) carry 7 marks.
 iv) Except numericals, Derivation, Design and Drawing etc.

1. a) Explain how control systems are classified.
 b) Distinguish between feedback control system and feed forward control system.
 c) Explain Mason's gain formula with an example.
 d) Write the differential equations governing the mechanical system shown in figure.

Also draw the force-voltage and force-current analogous circuit.

[2]

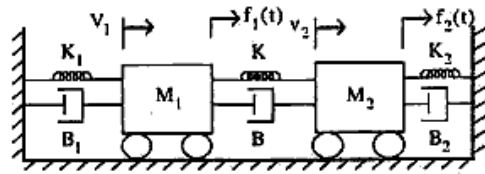

OR

Using block diagram reduction techniques obtain C/R by reducing the block diagram shown below.

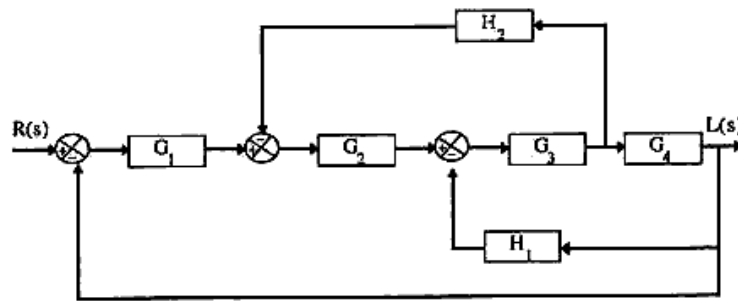

2. a) Define steady state response and steady state error.
- b) Explain BIBO stability.
- c) Explain the effect of addition of zero to the system. With suitable example.
- d) Sketch the root locus of the system whose open loop

transfer function is $G(s) = \frac{K}{s(s+2)(s+4)}$. Find the

value of K so that the damping ratio of the closed loop system is 0.5.

OR

Construct Routh array and determine the stability of the system whose characteristic equation is $s^6 + 2s^5 + 8s^4 + 12s^3 + 20s^2 + 16s + 16 = 0$. Comment on the location of the roots of characteristic equation.

[3]

3. a) Why Nyquist path does not contain L.H.S. of s-plane?
- b) What is Polar plot? Explain polar plot for Type 0 and Type 1 systems.
- c) Explain the concept of gain margin and phase margin. Explain how these values help in relative stability.
- d) Sketch Bode plot for the following transfer function and determine the system gain K for the gain cross over frequency to be 5rad/sec.

$$G(s) = \frac{Ks^2}{(1+0.2s)(1+0.02s)}$$

OR

Explain in detail about M and N circle.

4. a) What is compensation? Discuss various types of compensators.
- b) What is proportional plus derivative controller?
- c) Discuss integral and PID compensator.
- d) Write down the properties of Z-transform and define Z-transform.

OR

Obtain inverse Z-transform for the following :

$$X(z) = \frac{8z-19}{(z-2)(z-3)}$$